



Série RL

- ☒ Queimadores a gasóleo de 2 escalões
- ☒ Regulação externa da cabeça de combustão e do ar
- ☒ Fecho de ar na posição de “desligado” por servo-motor
- ☒ Ventilação estabilizada
- ☒ Carenagem para isolamento acústico
- ☒ Equipado de série com mangueiras flexíveis, junta de isolamento para a flange
- ☒ Certificação CE



| Modelo | kW | Peso (kg) |
|-----------|-----------------|-----------|
| RL 34 MZ | 97/154 - 395 | 32 |
| RL 44 MZ | 155/235 - 485 | 33 |
| RL 50 | 148/296 - 593 | 39 |
| RL 64 MZ | 206/391 - 830 | 42 |
| RL 70 | 255/474 - 830 | 60 |
| RL 100 | 356/711 - 1186 | 63 |
| RL 130 | 486/948 - 1540 | 66 |
| RL 190 | 759/1423 - 2443 | 75 |
| RL 250 MZ | 600/1250 - 2700 | 140 |

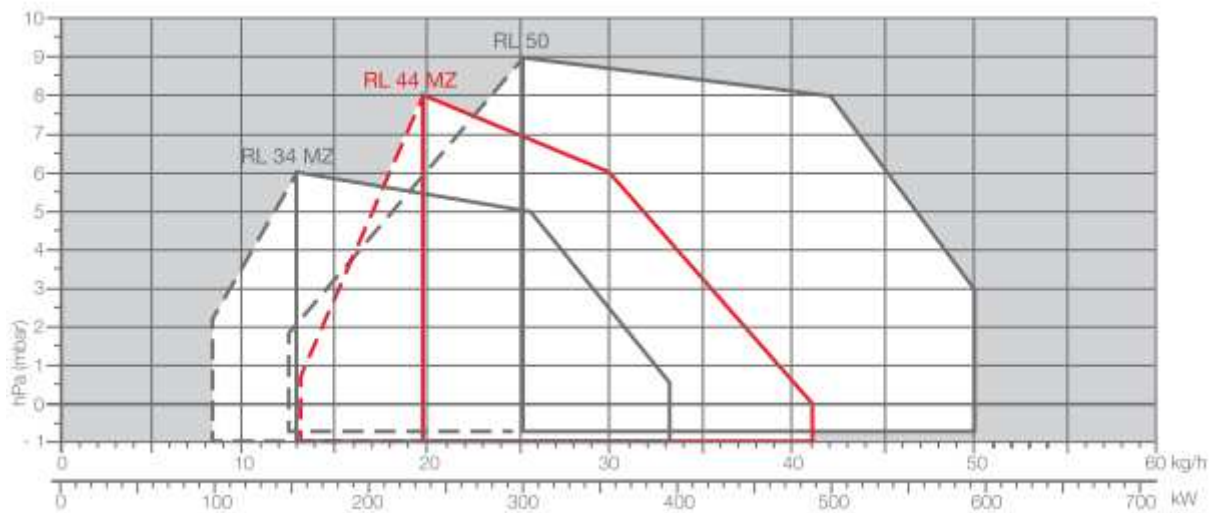

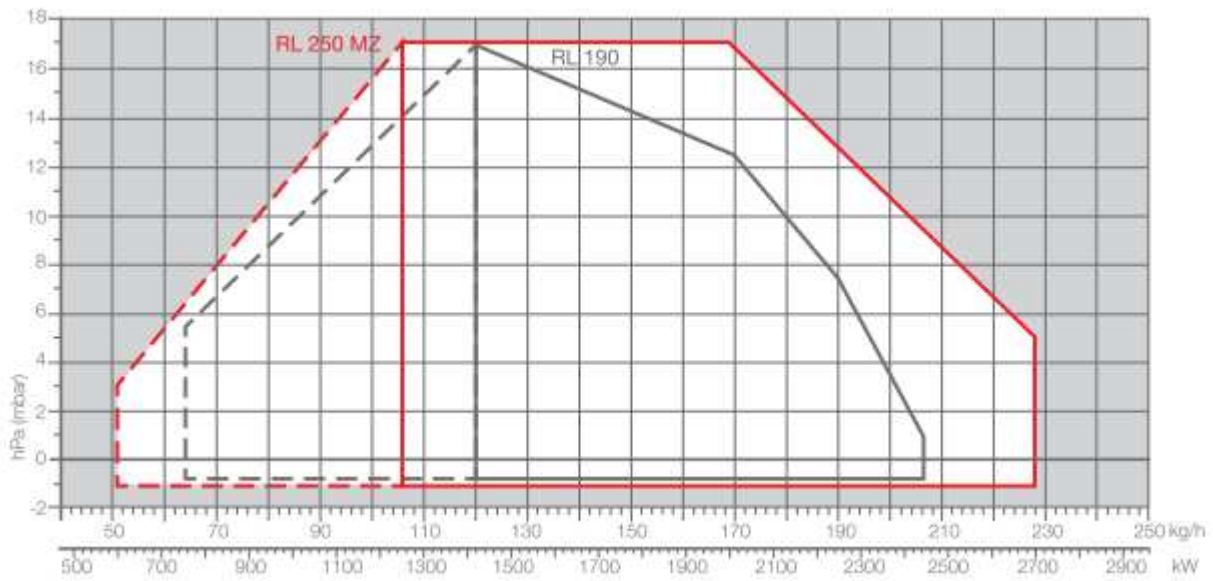
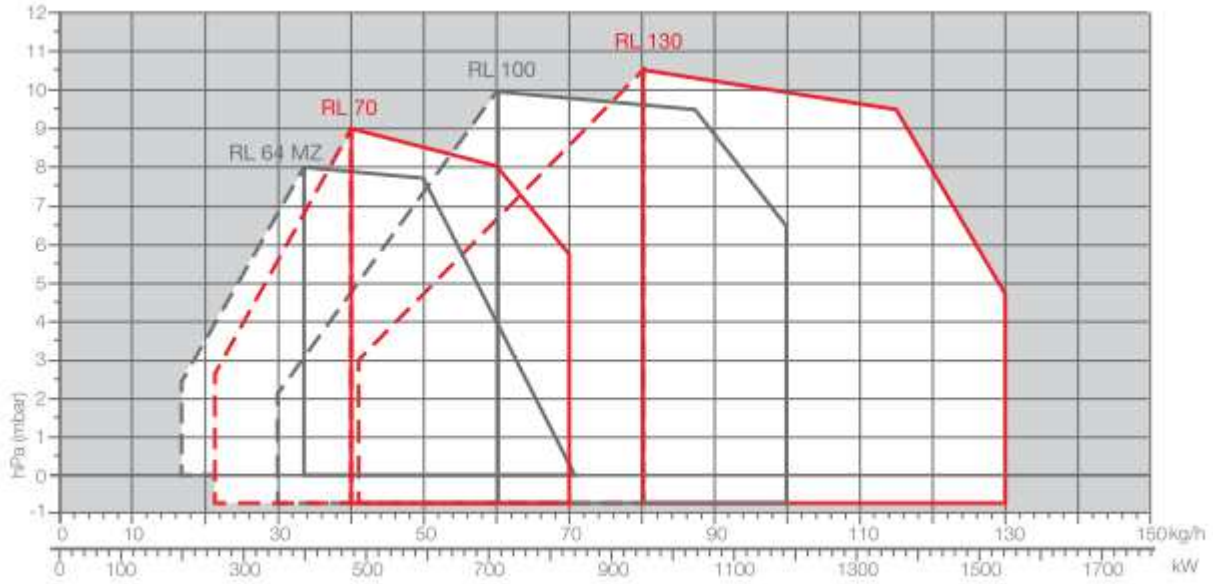



RL 34 - 44 MZ

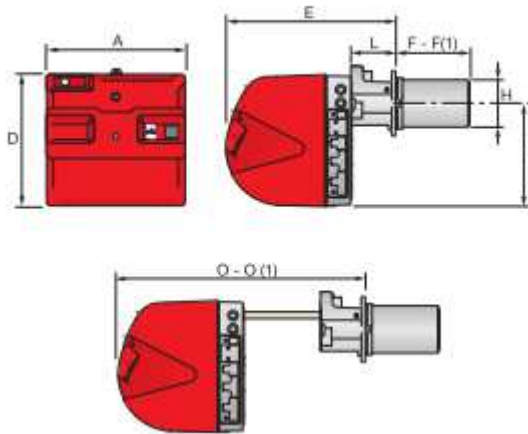

RL 50

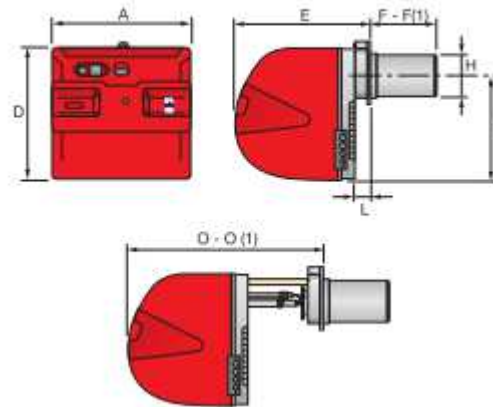

| Modelo | A (mm) | D (mm) | E (mm) | F - F(1) (mm) | H (mm) | I (mm) | L (mm) | O - O1 (mm) |
|----------|--------|--------|--------|---------------|--------|--------|--------|-------------|
| RL 34 MZ | 442 | 422 | 508 | 216-351 | 140 | 305 | 138 | 780-915 |
| RL 44 MZ | 442 | 422 | 508 | 216-351 | 152 | 305 | 138 | 780-915 |
| RL 50 | 476 | 474 | 468 | 216-351 | 152 | 352 | 52 | 672-807 |

(1)-Dimensão com kit de extensão de bocal instalado

RL 64 MZ

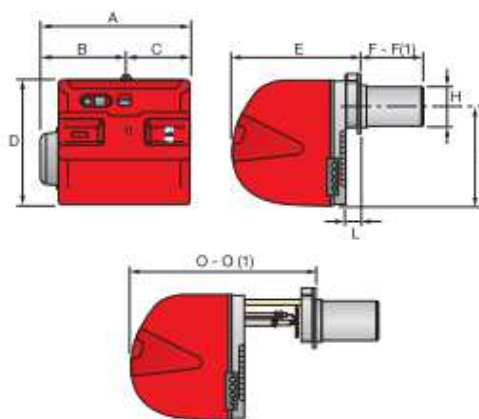

RL 70 - 100 - 130 - 190 - 250 MZ

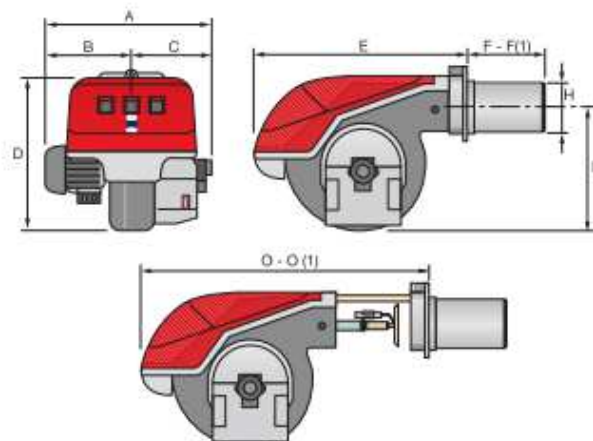

| Modelo | A (mm) | B (mm) | C (mm) | D (mm) | E (mm) | F-F(1) (mm) | H (mm) | I (mm) | L (mm) | O - O1 (mm) |
|-----------|--------|--------|--------|--------|--------|-------------|--------|--------|--------|-------------|
| RL 64 MZ | 538 | 300 | 238 | 490 | 477 | 250-385 | 179 | 335 | 60 | 680-815 |
| RL 70 | 580 | 296 | 284 | 555 | 680 | 250-385 | 179 | 430 | - | 951-1086 |
| RL 100 | 599 | 312 | 287 | 555 | 680 | 250-385 | 179 | 430 | - | 951-1086 |
| RL 130 | 625 | 338 | 287 | 555 | 680 | 250-385 | 189 | 430 | - | 951-1086 |
| RL 190 | 756 | 366 | 390 | 555 | 712 | 370-5630 | 222 | 460 | - | 1166 - - |
| RL 250 MZ | 910 | 432 | 478 | 555 | 705 | 378-528 | 222 | 436 | - | 1166 - - |

(1)-Dimensão com kit de extensão de bocal instalado